

# B2X

## Bidirectional 6 digit multifunction counter - DIN 96x48



REEL TORINO data sheet

DL3UK0002A0

### **SPECIFICATIONS**

- ✓ **Two inputs counter: UP, DOWN, UP & DOWN max 10 KHz**
- ✓ **Input signals from: NPN, PNP, potential free mechanical contact**
- ✓ **Pulse-weight programmable for totaliser**
- ✓ **Available versions with 2, 4, 6 presets**
- ✓ **Double analog outputs 4..20mA & 0..10Vdc**
- ✓ **Serial communication: Field bus type MODBUS RTU (RS485) or double RS232 ports**

### **VERSIONS**

The following versions are available:

- Indicator (6 preselections max): B2X\_\_
- Indicator with double analog output (4 preselections max): B2X\_\_T
- Indicator with MODBUS RTU port (4 preselections max): B2X\_\_D
- Indicator with RS232 double serial port (4 preselections max): B2X\_\_R.

### **APPLICATION & PERFORMANCE**

Dosing, predetermination, batch controls, visual display, control of linear and angular displacements: here only some of the possible applications of B2X series .

B2X programmable bidirectional pulse counters can be applied in all industrial environments such as water distributions, paper factories, mechanical, iron, food, chemical, pharmaceutical industries and more. B2X units allow the acquisition, totalization and predetermination of signals coming from industrial sensors such as photoelectric cells, proximity switches, incremental encoders (angular positions), optical lines (linear positions), mechanical limit switches, free contacts .

Through two inputs, it is possible to carry out incremental (UP) and decremental (DOWN) counts, with the UP/DOWN (FIFO) double possibility, with the totalized amount of pulses received from the two inputs.

It is possible to assign a pulse weight in order to adjust the count ratio for: volumetric counters (pulses per litre), meter counters (development/revolution); application of encoders (or sensors) on existing mechanical components (the mathematic resolution allowed is equal to 1/999999).

The offset function (preset) allows to force the count to a value different from zero.

Should the power supply be off, the count is kept by an EEPROM indelible memory .

A simple programming by a 4-key touch-panel keyboard and a highly efficient 6-digit LED display make the device easy to use .

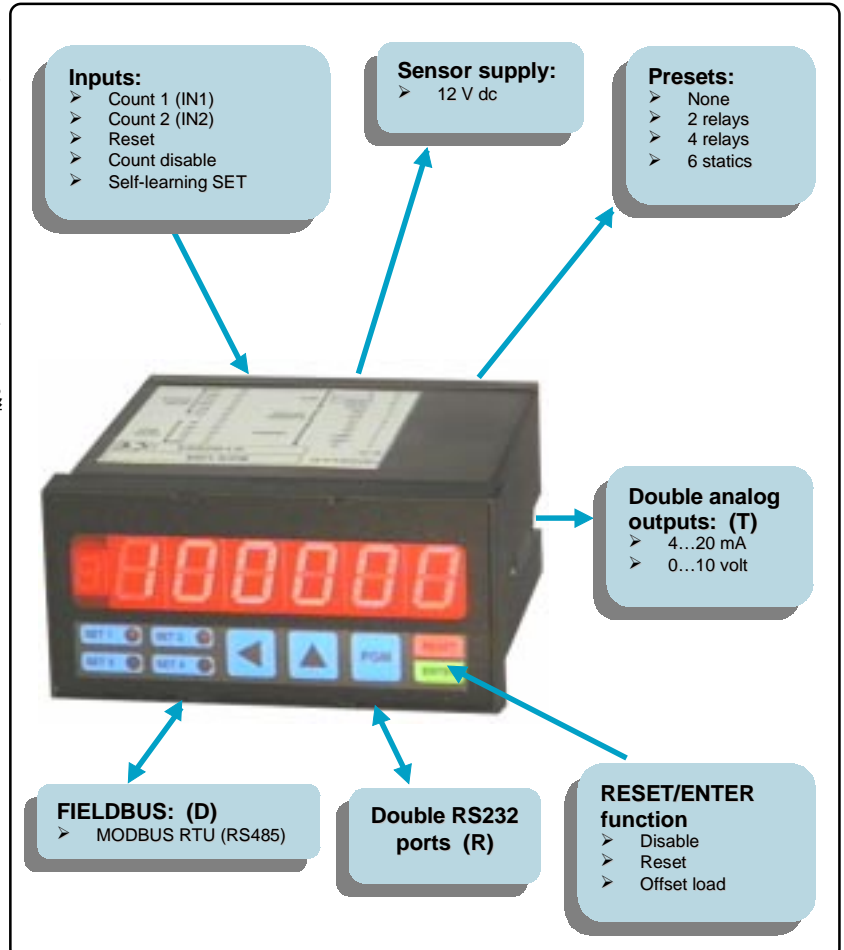

Reliability

# B2X

## Bidirectional 6 digit multifunction counter - DIN 96x48



### TECHNICAL DATA

#### PACKAGE

Case: panel mount 96x48 mm frontal IP54  
 Cutout dimension: 92x45 mm; depth: 100 mm  
 Case material: Noryl  
 Keyboard: 4 membrane push buttons  
 Connections: by extractable terminal block

#### DIGITAL INPUT

Signal: NPN or PNP configurable  
 Voltage: 10...30Vdc; impedance: 2200 ohm  
 Sensor supply: 12 Vdc – maximum 60 mA  
 IN1, IN2: count input maximum 10KHz speed (debouncing filtre programmable)  
 RST1: zeroing input or offset loading  
 RST2: SET self learning input  
 GT: count block input

#### COUNTER AND DISPLAY

Display (red led): 6+1 digit (polarity), max displayed value ±999999  
 Character high: 12,5 mm  
 Decimal point: programmable  
 Counter: ± 31 bit

#### POWER SUPPLY

Power supply: 24, 115, 230Vac, 24Vdc [1], 24VDCI [2]  
 Consumption: max 3,3 VA (3,3 W)  
 Tolerance: ± 10 %; frequency (AC): 50/60 Hz  
 Data storage memory: EEPROM static memory

#### AMBIENTAL CONDITIONS

Operating temperature: -10 ÷ 50 °C  
 Relative humidity: 0...95% not condensing  
 Storage temperature: -25 ÷ 70 °C

[1] 24Vdc power supply not galvanically insulated version: negative input signal short-circuit to negative power supply

[2] 24Vdc power supply galvanically insulated version

#### PRESELECTION AND OUTPUTS

Preselections: 2, 4 relays 5A / 250V  
 6 static NPN 30mA/5...30V  
 Cycle: manual or automatic selectable  
 Automatic cycle time: 0,01...99,99 sec.  
 Cunt direction: increasing / decreasing

#### DOUBLE ANALOG OUTPUT (T option) [3]

Proportional to display value; start of scale and end of scale position programmable  
 Signals: 0-10Vdc (minimum load 1Kohm)  
 4-20mA (maximum load 250 ohm)

Resolution: 2000 points  
 Accuracy: 0,01 %;  
 Linearity: 0,0025 %

#### RS485 SERIAL PORT - MODBUS (D option) [3]

Communications protocol: MODBUS RTU  
 Profile: all parameters  
 Baud rate: 300...19200 baud  
 Address: range 1... 247 (0 – broadcast)  
 Configuration: 8 bit data; parity none; 1 stop bit

#### DOUBLE RS232 SERIAL PORT (R option) [3]

Protocol: read ing / writing internal register  
 Baud rate: 150...9600 baud  
 Address: range 1... 254  
 Configuration: 8 bit data; parity none; 1 stop bit

#### CONFORMITY TO CEE GUIDELINES

CEE 93/68  
 CEE 89/336 (EMC)  
 CEE 73/23 (BT)

[3] the above mentioned technical references are related to the B2X versions chosen.

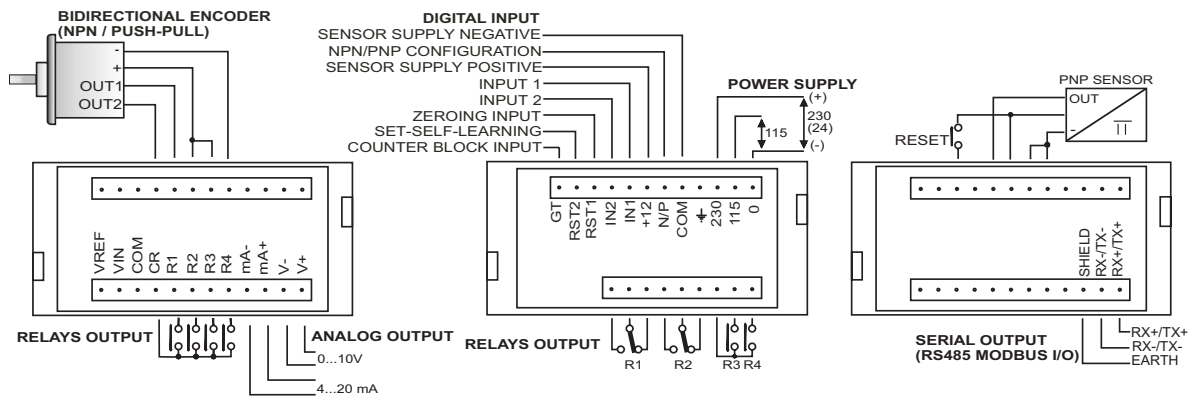
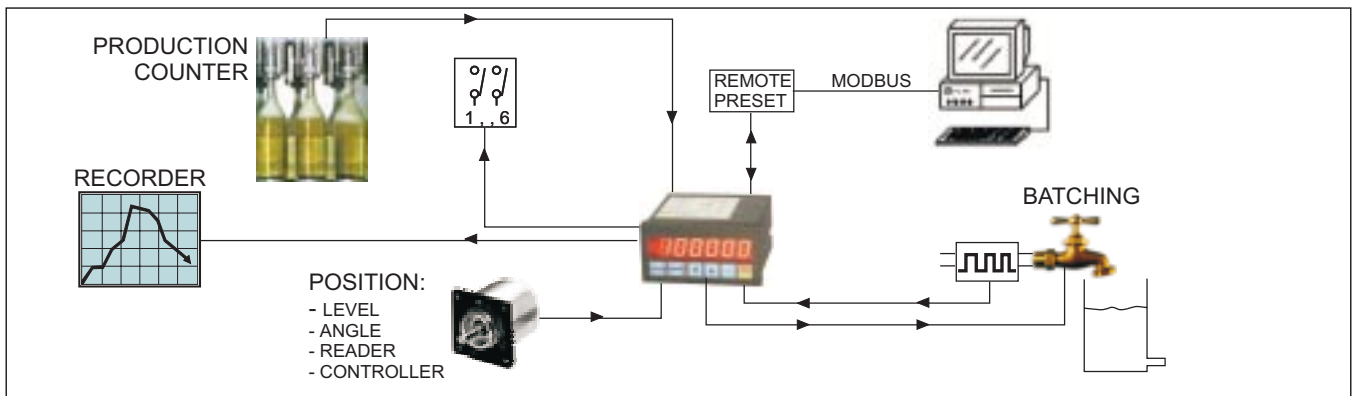

#### REEL Torino

via Aosta 5 - 10044 - Pianezza (TO)  
 tel. +39-011 9661171 - telefax +39-011 9661271  
 http: www.reeltorino.it  
 e-mail: international@reeltorino.it

Reliability