

- FM Radio Transmitter & Receiver
- RF Transceiver or Intelligent Modem Versions
- Data Rates to 20 K baud.
- 2 Selectable RF Channels
- Narrowband Crystal Controlled
- Optimal Range 200m
- Supply Voltage 3-5V
- Very Stable Operating Frequency
- Low Profile Ceramic DIL Package
- Operates from -20 to +85°C

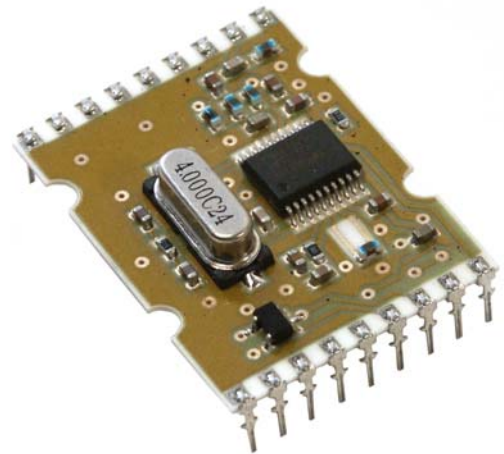

### Applications

- Wireless Security Systems
- EPOS Terminals
- Sensor Data logging
- Remote Telemetry & Telecommand
- Remote Meter Reading

### RXQ1 Version

- RF Transceiver Version Only

### TRXQ1 Version

- Transceiver With RF600T Incorporated
- Serial Data Interface with Handshake
- Selectable Dumb or Intelligent Modem Modes

### Description

The RXQ1 / TRXQ1 radio transceiver modules provide reliable wireless communications for the transfer of data at rates of up to 20 K baud. Their unique features of narrow band operation and user channel selection combined with excellent interference rejection make them an ideal choice for next generation applications.

Operating within the 433.92MHz frequency band the modules can operate in two narrow band channels; 433.92 MHz and 433.33MHz. The modules use a crystal controlled design which provides narrow band performance which is far superior to other wideband 'SAW' based designs.

Supplied as either a basic wireless transceiver or as a modem transceiver incorporating the RF600T encoder/decoder controller these modules allow simple interface to microcontrollers, async. serial data sources, PC's etc.

Possible applications include one-to-one and multi-node wireless links in applications including car and building security, EPOS and inventory tracking, remote industrial process monitoring and computer networking. Because of their small size and low power requirements, both modules are ideal for use in portable, battery-powered applications such as hand-held terminals.

### Part Numbering

Part Number	Description
440006132	Transceiver Module 433MHz
440008014	Transceiver Module 433MHz with RF600T Incorporated

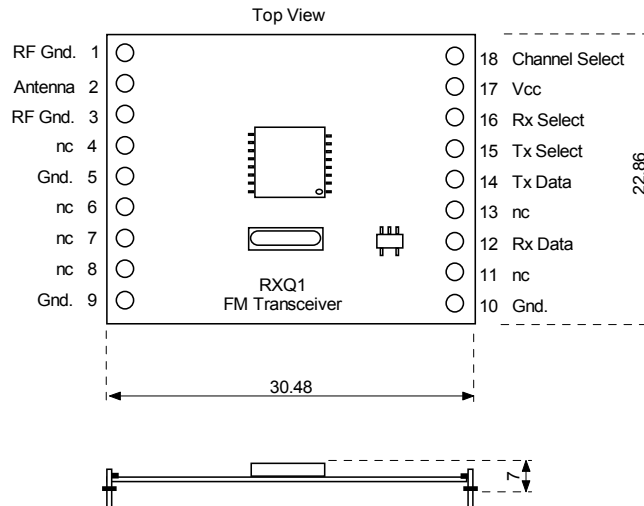
**RXQ1 Pinout Detail**

**Pin Descriptions**

Pin Number	Name	Type	Description
1,3	<b>RF GND</b>	In	For best results, these pins should be connected to the ground plane against which the antenna radiates.
2	<b>Antenna</b>	In / Out	Nominal 50 ohm input/output impedance capacitively isolated from the internal circuit.
4, 6, 7, 8, 11, 13	<b>nc</b>	-	No Connection
5, 9, 10	<b>GND</b>	In	Connect to 0 volts.
12	<b>Rx</b>	Out	Received data output to host controller (CMOS logic out) representing true data as supplied to the transmitter.
14	<b>Tx</b>	In	Transmit data input from host controller Data input to the transmitter can be directly interfaced to CMOS logic drive operating on the same supply voltage as the transceiver
15	<b>Tx SELECT</b>	In	Transmit select. Active LOW.
16	<b>Rx SELECT</b>	In	Receive select. Active LOW.
17	<b>Vcc</b>	In	Positive supply voltage connection. Decouple with 100n ceramic capacitor to ground.
18	<b>CS</b>	In	Channel Select; Logic 0 selects 433.92MHz Logic 1 selects 434.33MHz

**Operation Table**

Tx Select	RX Select	Function
0	0	Power Down Mode
0	1	Transmit Mode
1	0	Receive Mode
1	1	Power Down Mode

**RXQ1 Operating Parameters**
**Absolute Maximum Ratings**

Operating temperature:	-20 °C to +70 °C
Storage temperature:	-40 °C to +100 °C
Supply Voltage	-0.3 to 6V
Data input	-0.3 to Vcc + 0.3v

**Electrical Characteristics:**

	Min.	Typ.	Max.	Units	Notes
<b>DC Levels</b>					
Supply voltage	2.7	3	5.25	V	1
Supply current (Transmit Mode)		26		mA	
Supply current (Receive Mode)		12		mA	
Supply current (Standby Mode)		8		uA	
Data input/output high	0.7xVcc		Vcc	V	
Data input/output low	0		0.3xVcc	V	
<b>RF</b>					
Working Frequency		433.92 / 433.33		MHz	
Receiver sensitivity		-100		dBm	
RF power out (transmitter)		5		dBm	Into 50Ω
FM Deviation		+/- 15		KHz	
IF Bandwidth	65		85	KHz	
Harmonic Spurious Emissions		-50		dBc	
Operating Temperature	-20		+70	Deg C	
<b>Dynamic Timing</b>					
Power up to stable receiver data out		5		mS	2
Power up to full RF out		4		mS	2
Standby to RX mode		3		mS	
Standby to TX mode		2		mS	
Changing from TX to RX mode		3		mS	
Changing from RX to TX mode		1		uS	
Data Bit rate	20		20,000	bps	

**Notes**

1. Supply voltage should have <10mV ripple.

**RXQ1 Applications**

The RXQ1 is a dual band 'transceiver only' RF module which has applications in many areas where reliable half duplex communications are required over ranges up to 200 metres. The crystal controlled narrow band design gives optimum performance in the 433 MHz band and the dual channel capability allows for the design of more complex networks than had previously been possible.

## DUAL BAND FM WIRELESS TRANSCEIVERS

### RXQ1 Application Information with RF600T

The circuit below shows a typical application of the RXQ1 in conjunction with the RF600T low power radio transceiver controller. A 9 way 'D' connector provides an RS232 termination to the host system and the RXQ1 hybrid contains all of the circuitry required to implement the RF path. The RF600T operates as a transceiver controller and performs all of the functions necessary to implement either a 'dumb' or an intelligent modem with automatic retry and proof of deliver functions built in to the system. In many applications it will be possible to dispense with the option links and hard-wire options to their desired settings but note however option selection must be carried out exactly as described in the RF600T data sheet.

This implementation of TRXQ1 module and RF600T is available as the composite hybrid TRXQ1 which is described in this data sheet.

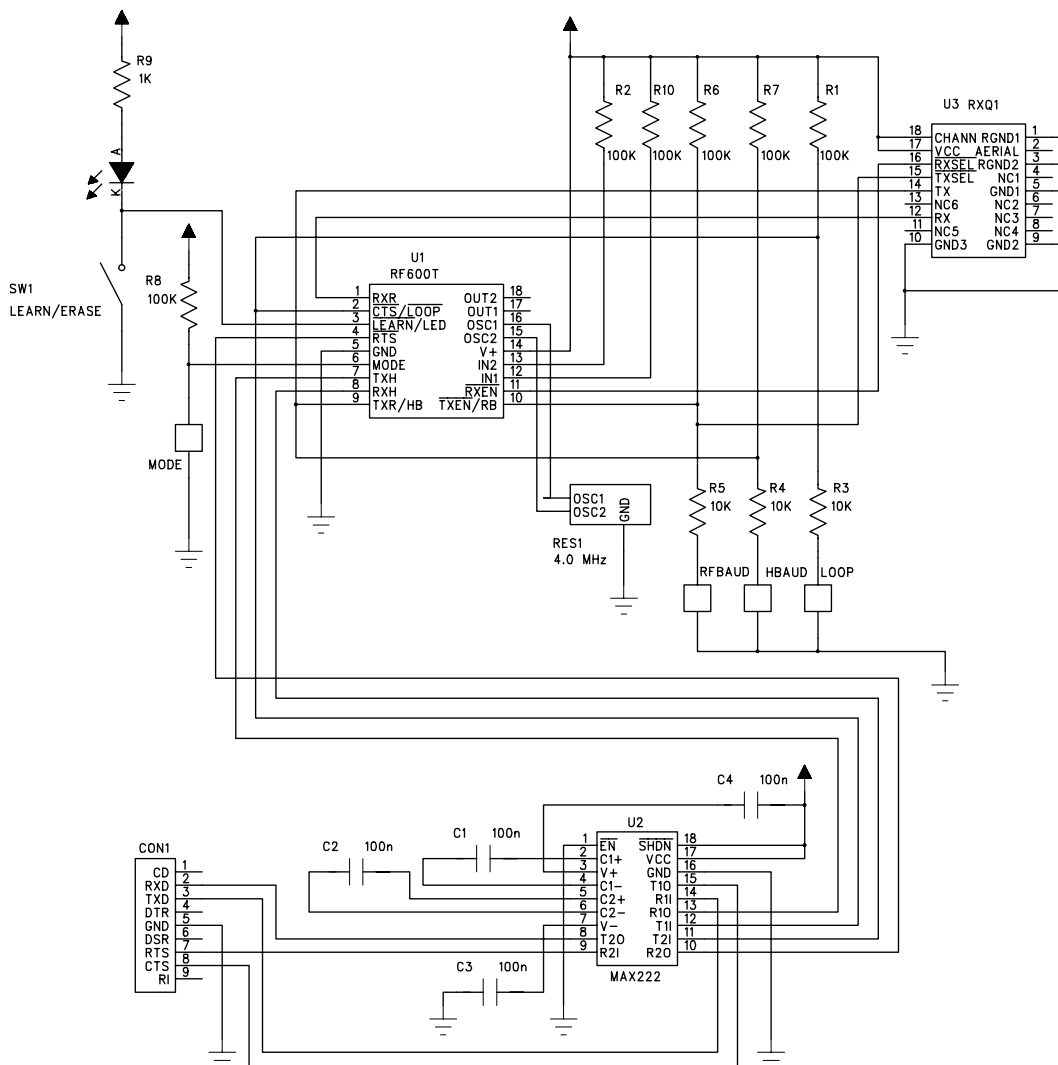

## TRXQ1 Pinout Detail

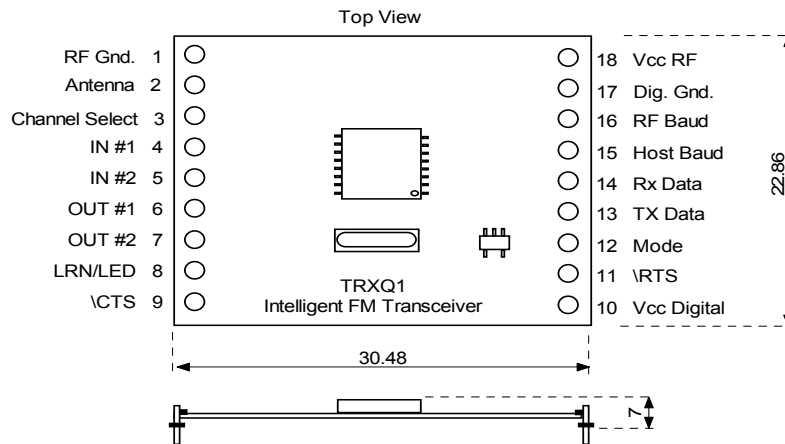

## Pin Descriptions

Pin Number	Name	Type	Description
1	<b>RF GND</b>	Power	For best results, this pin should be connected to the ground plane against which the antenna radiates.
2	<b>Antenna</b>	In / Out	Nominal 50 ohm input/output impedance capacitively isolated from the internal circuit.
3	<b>CS</b>	In	Channel select option. Logic 0 selects 433.92MHz Logic 1 selects 434.33MHz
4	<b>IN #1</b>	In	Logic input #1
5	<b>IN #2</b>	In	Logic input #2
6	<b>OUT #1</b>	Out	Logic output #1
7	<b>OUT #2</b>	Out	Logic output #2
8	<b>LRN/LED</b>	In/Out	Learn switch and status LED.
9	<b>\CTS (loop)</b>	Out	Logic '0' is Clear To Send. Connect to 0 volts via 10K to enable loop mode.
10	<b>Dig Vcc</b>	Power	Positive supply voltage connection.
11	<b>\RTS</b>	Out	Logic '0' is Request To Send.
12	<b>MODE</b>	In	Mode select option. Logic '1' or open selects intelligent mode. Logic '0' selects 'dumb' mode.
13	<b>TxData</b>	In	Serial async. data input from the host.
14	<b>RxData</b>	Out	Serial async. data output to the host.
15	<b>Host Baud</b>	In	Host baud rate selection option. Logic '1' or open selects 9600 bauds. Logic '0' selects 2400 bauds.
16	<b>RF Baud</b>	In	RF baud rate (element time) select option. Logic '1' or open selects 400 us element time. Logic '0' selects 200 us element time.
17	<b>GND</b>	Power	0 volts.
18	<b>VccRF</b>	Power	RF supply voltage connection. Level to be as Vcc Digital on pin 10 Decouple with a 100nF capacitor close to the module supply pins.

**TRXQ1 Operating Parameters**
**Absolute Maximum Ratings**

Operating temperature:	-20 °C to +70 °C
Storage temperature:	-40 °C to +100 °C
Supply Voltage	-0.3 to 6V
Data input	-0.3 to Vcc + 0.3v
Maximum output current	+/- 25 mA

**Electrical Characteristics:**

	Min.	Typ.	Max.	Units	Notes
<b>DC Levels</b>					
Supply voltage	3.0	5.0	5.25	V	1
Supply current (Transmit Mode)		28		mA	
Supply current (Receive Mode)		14		mA	
Data input/output high	0.7xVcc		Vcc	V	
Data input/output low	0		0.3xVcc	V	
Output Pin Current rating		-	25	mA	
LED sink current		5.0	25	mA	
<b>RF</b>					
Working Frequency		433.92 / 433.33		MHz	
Receiver sensitivity		-100		dBm	
RF power out (transmitter)		5		dBm	Into 50Ω
FM Deviation		+/- 15		KHz	
IF Bandwidth	65		85	KHz	
Harmonic Spurious Emissions		-50		dBc	
Operating Temperature	-20		+70	Deg C	

**Notes**

1. Supply voltage should have <10mV ripple.

**TRXQ1 Design Data**

The TRXQ1 is an intelligent dual band communications module consisting of the RXQ1 transceiver circuitry and an RF600T embedded controller IC. Designers should study the RF600T data sheet (DS601) since this contains detailed information on the operation of this device. The design information given below should be read in conjunction with this data sheet.

The embedded controller IC used in this hybrid (PIC16F628) is a flash programmable device and can be on board programmed (see below). The TRXQ1 hybrid may thus be user programmed for other custom applications.

---

## TRXQ1 Operating Modes

The device is capable of operation in one of two modes, either broadcast or addressed. The following description describes the features of these mode and assumes two TRXQ1 nodes 'A' and 'B'. The RF600T must be configured before power up for either the broadcast or addressed mode of operation by means of the MODE pin. Note that for security, broadcast nodes will not receive data from addressed nodes

### Broadcast mode.

This mode allows a host generated data block from node 'A' to be transmitted and received by any number of other nodes. This data is received and verified (for correct Manchester coding and CRC) by the other nodes before being output to their host devices. Alternately, in the same way the other nodes can send data to node 'A'. Note that although any node can initiate a transfer, only one direction of transfer can be active at a given time. Correct reception of a data packet is not acknowledged and the node hosts have the responsibility of ensuring that data transfers occur as required by operating some form of message protocol over the half duplex data link.

### Addressed mode

This mode allows a host generated data block from node 'A' to be transmitted and for the data frame to be addressed to one other network node – in this case we assume node 'B'. When the data is received by node 'B' it is verified for correct Manchester coding, CRC and for address match and then an acknowledge message is transmitted back to node 'A'. Node 'A' then outputs a confirmation to the host in the form of the ASCII character 'C' (Confirmed). Note that confirmation is given when the data block is stored in the buffer of node 'B' and not when it has been delivered to the host at node 'B'.

All message transfers are tagged with the addresses of both the origin and destination, thus ensuring secure data transfer at all times. Either node 'A' or node 'B' can initiate a transfer but only one direction of transfer can be active at a given time. In the event that the originating node does not get confirmation of receipt of the data packet, the software re-tries the transfer five times after which node 'A' will output an error message to the host in the form of the ASCII character 'F' (Failed).

Correct reception (or otherwise) of a data packet is thus acknowledged and the host devices are relieved of most of the workload of ensuring that data transfers occur as required.

The RF600T must be configured before use for either the broadcast or addressed point to point mode of operation and details of how this is carried out are given in the following section.

## System Operation

Each RF600T is programmed at manufacture with a 24 bit serial number which uniquely identifies the device. In an addressed point to point system, these serial numbers are used as the device address for the nodes in the system and non-volatile eeprom memory in the device stores the address of the 'other' node in the system. If, as at time of manufacture, no address has been stored in the device or if the address has been erased then the device will only operate in the broadcast mode. If however an address has been stored then the device will only operate in the addressed point to point mode.

---

If operation in the broadcast mode is required then with a new device, no action is necessary. If a device has been used in the point to point addressed mode or if its status is unknown then status erase must be carried out using the following procedure.

The LEARN pin is grounded for a period of 5 seconds and is then allowed to float. The status LED then flashes slowly for 3 seconds to indicate that the device is erased and will now only operate in the broadcast mode.

If operation in the addressed mode is required then the following procedure has to be followed to allow the two nodes in the system to operate together.

The two nodes, 'A' and 'B' are placed within radio range of one another are powered up.

The LEARN pin on one device – say 'B' is briefly taken low, placing the node into learn mode. The LEARN/ERASE status LED on 'B' comes on and remains on for 20 seconds. If within this period, no 'learn' data packet is received (see below) then the LED will be extinguished and the device will operate normally.

At node 'A', the LEARN pin is briefly taken low. The LEARN/ERASE status LED will then come on and node 'A' will transmit its address.

Node 'B' will receive and store the address of 'A'.

Node 'B' sends back to node 'A' both its address and that of node 'A'.

Node 'A' receives and stores the address of 'B' and confirms to 'B' that it has received the its address.

Both node 'A' and 'B' LED's flash their its status LED's rapidly for 3 seconds to show that they have learned each others addresses.

(other nodes which may be active will ignore this transfer since they have not been placed in the learn mode)

#### **LRN/LED pin (addressed mode only)**

The learn/LED pin is used both to sense the learn/erase switch and also to drive the indicator LED and should be connected as shown in the RXQ1 application circuit. The switch, which should be of the normally open type, should be connected from the learn pin to ground. The LED and its series current limiting resistor should be connected from Vcc to the learn pin, ensuring that the maximum current drawn by the LED (as given in this data sheet) is not exceeded.

#### **TRXQ1 Loop Mode**

Loop mode is provided to allow testing of the performance of a system and allows node 'A' to transmit a data packet which will be looped back by node 'B' and received by node 'A'. The mode settings of the nodes are ignored in the loop mode and the transfer is carried out in broadcast mode. The mode must only be selected when there are just two nodes in a network.

If we assume that we wish to send a host data packet from node 'A' to node 'B' and have the packet returned such that host 'A' receives back its data packet then the LOOP link in node 'A' should be made before that unit is powered up. This unit will now only operate in the loop mode until it is powered down, the loop link removed and then powered up again.

## TRXQ1 application schematic: RS232 connection to host PC.

Connection of the TRXQ1 to an RS232 host terminal device such as a PC serial port can be simply carried out using the circuit shown below. The 9 way 'D' socket (CON1) provides the standard pinout required to connect directly to the serial port of any PC using a 9 way male/female cable. The MAX222 provides level conversion between the RS232 levels on the serial port and the logic levels pins of the TRXQ1 module. (note that direct connection of RS232 levels to the module will result in immediate destruction of the device)

The TRXQ1 hybrid requires the following 4 signal connections to operate correctly:

- Tx Data: this is serial data which is to be transmitted by the hybrid.
- Rx Data: this is serial data which has been received by the hybrid.
- \CTS: this control output to the host is low when it is Clear To Send data to the hybrid.
- \RTS: this control input from the host is low when it is making a Request To Send data from the hybrid.

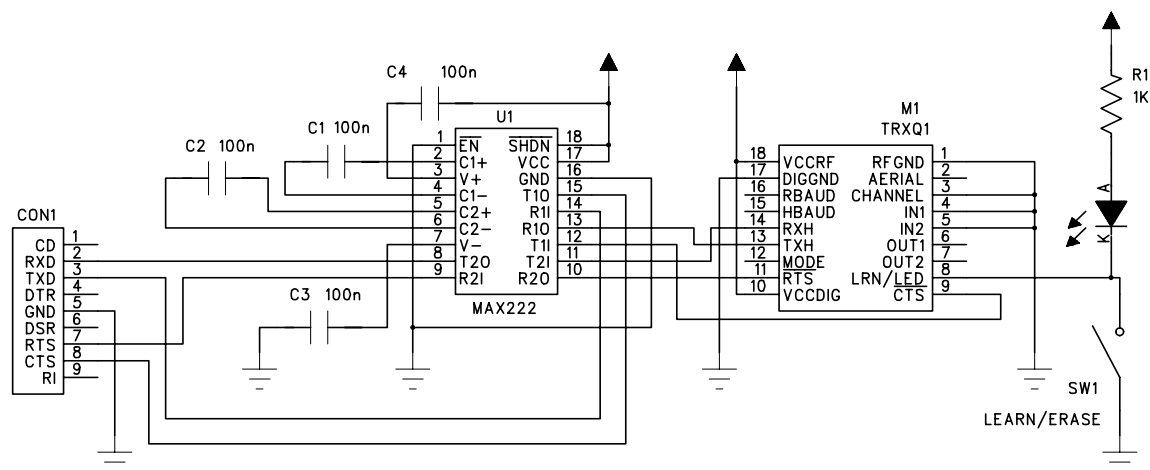

In this circuit, option selection is as follows:

- RF Baud rate (pin 16): this pin is left open circuit which selects 9600 bauds.
- Host Baud Rate (pin 15): this pin is left open circuit which selects 400 us element time.
- Mode (pin 12): this pin is left open circuit which selects addressed mode.

If two such circuits are constructed then it will be possible to interconnect two PC's and test out the performance of the hybrids. When both circuits are powered up it will be necessary for them to learn one another's identity as described fully in the RF600T data sheet (DS601). That is – press the learn switch in one circuit, then in the other and the two learn LED's should flash showing that the learn has taken place.

The addressed mode operates as a point to point half duplex system with automatic retry and indication to the transmitting host of the status of the transfer. Again the RF600T data sheet gives full information on this mode of operation.

**TRXQ1 application schematic: logic level connection to host micro controller.**

Direct connection of the TRXQ1 to a host micro controller allows the design of complex systems where the host micro controller provides all of the processing power and the TRXQ1 acts as the data carried between system nodes.

The use of the broadcast mode will allow multiple transceiver systems to be implemented and with suitable software and a user defined protocol it will be possible to implement complex networks where control of the data path, retries etc. are under the control of the designer.

Where a point to point system is required then the addressed mode will provide this and also give the required level of security. This, along with the automatic retry feature of the TRXQ1 module will remove from the system designer all of the normal overhead of writing communications software.

As was the case with the RS232 example given above, the TRXQ1 hybrid requires 4 signal connections to operate correctly.

- TxHOST: serial data which is to be transmitted by the hybrid.
- RxHOST: serial data which has been received by the hybrid.
- \CTS: control output to the host is low when it is Clear To Send data to the hybrid.
- \RTS: control input from the host is low when it is making a Request To Send data from the hybrid.

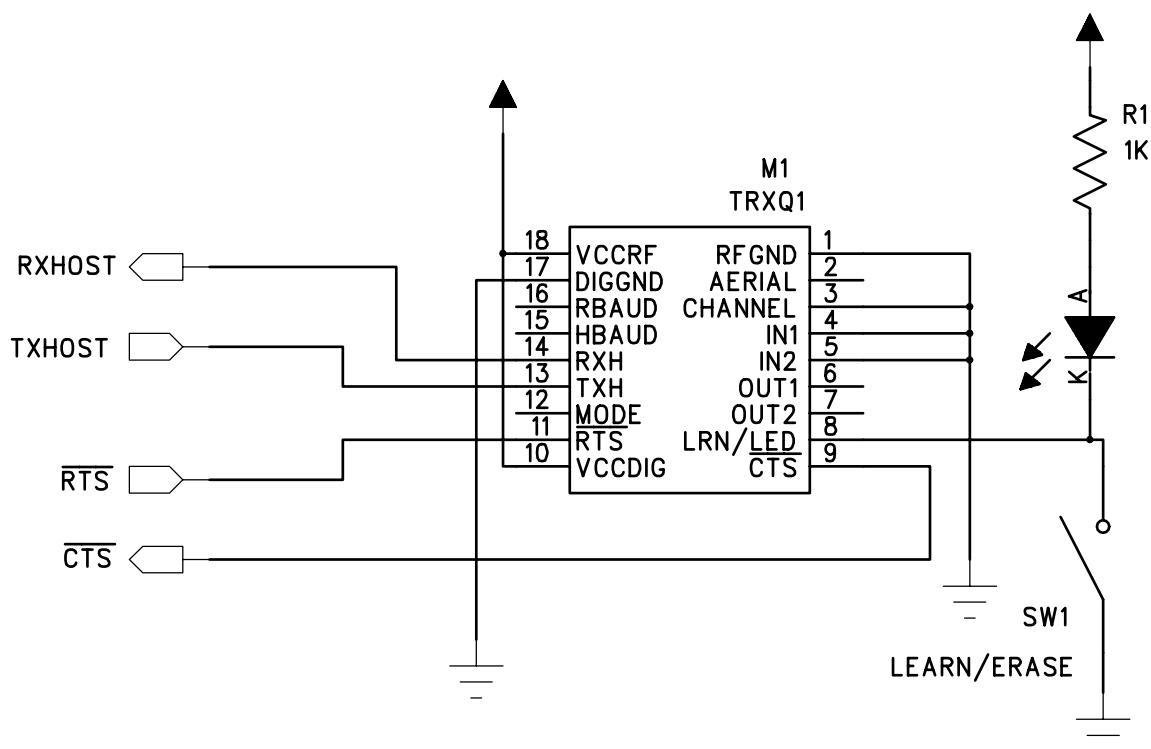

In some addressed mode applications the learn/erase components may not be required and the LRN/LED pin could be connected to the host micro controller which would be programmed to handle the functions of this pin.

Where the module is to be used in the broadcast mode then the learn/erase components will not be required which will lead to further simplification of the circuit.

## DUAL BAND FM WIRELESS TRANSCEIVERS

### TRXQ1 Customer Programming of Flash Micro Controller

The TRXQ1 hybrid incorporates a PIC 16F628A micro controller and the standard hybrid is factory programmed with the same code as the RF600T transceiver controller chip. Users who wish to implement their own control software can program the on-board PIC using the Microchip In Circuit Serial Programming system. Connection to the requisite PIC pins is made using five of the hybrid pins as shown in this circuit.

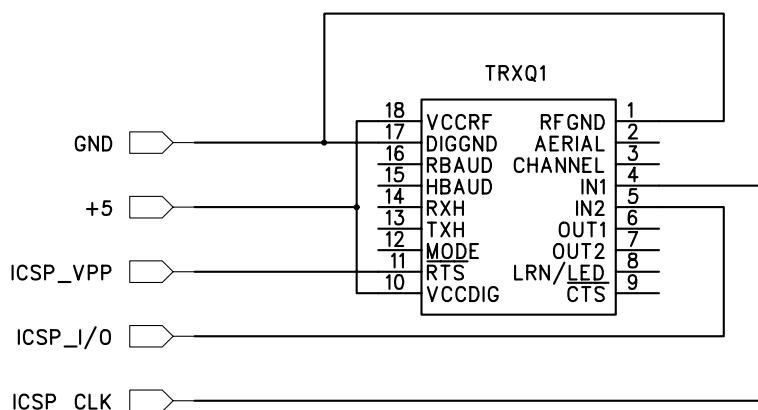

For those customers who have a specific application requirement but who do not wish to produce the necessary software, R. F. Solutions is able to offer a custom design capability and interested parties should contact the Sales Department for details.

### Antenna Design

The design and positioning of the aerial is as crucial as the module performance itself in achieving a good wireless system range. The following will assist the designer in maximising system performance.

The RF ground pin should be connected to a ground plane which should shield the aerial connection and the PCB layout around the aerial track itself should be such as to give a 50 Ohm impedance. The aerial should be kept as far away from sources of electrical interference as physically possible. The specified power supply decoupling capacitors should be placed close to the module as possible and have direct connections to the relevant pins.

The antenna 'hot end' should be kept clear of any objects, especially any metal as this can severely restrict the efficiency of the antenna to receive power. Earth planes restricting the radiation path of the antenna will also have the same effect.

The best range will be achieved with either a straight piece of wire, rod or PCB track @  $\frac{1}{4}$  wavelength (15.5cm @ 433.92MHz). Increased range may be achieved if this  $\frac{1}{4}$  wave antenna is placed perpendicular to and in the middle of a solid earth plane measuring at least 16cm radius. In this case, the antenna should be connected to the module using 50 Ohm coaxial cable and the PCB track layout tips given above should be observed.

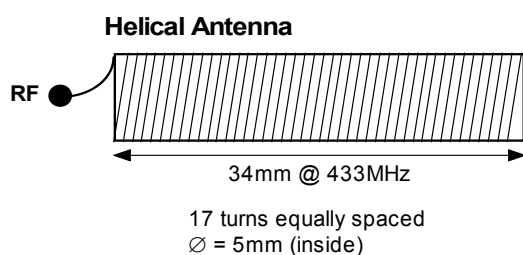

## Mechanical Detail

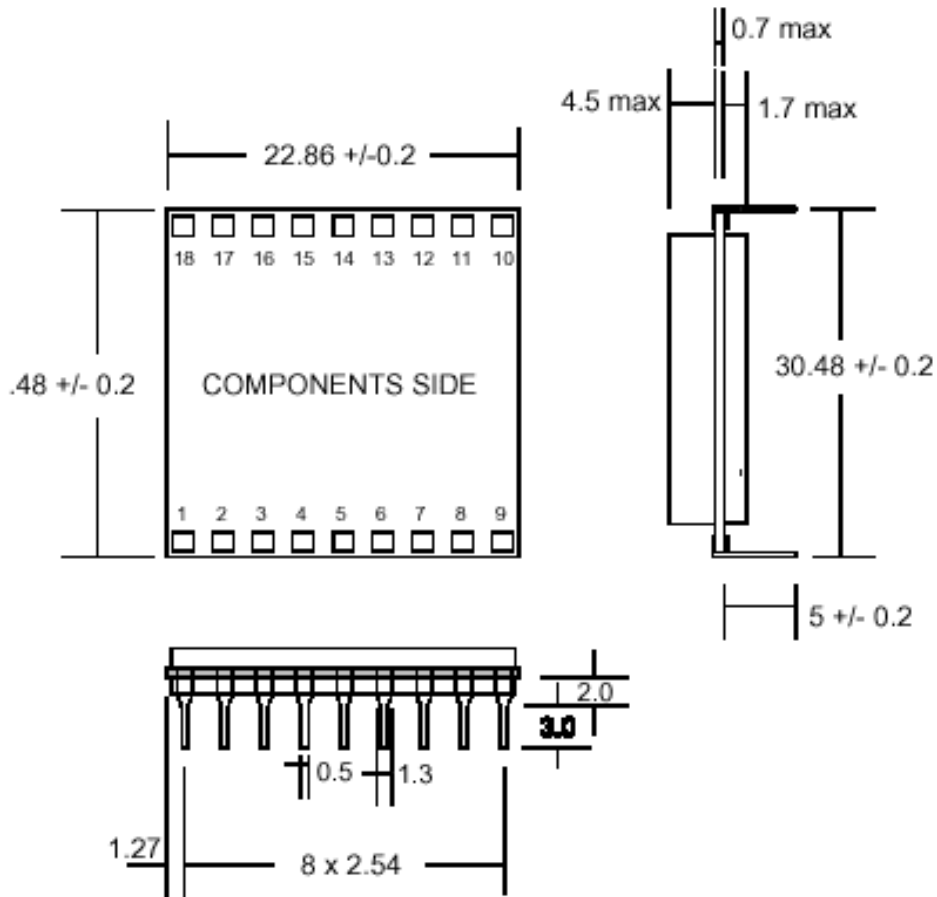

DIMENSIONS : MM